

RANGE COMPOSITION

Model consists of different models of hot cupboards with splashback, varying in length from 1000 to 2000 mm. Hot cupboards are ideal for storing and keeping crockery warm.

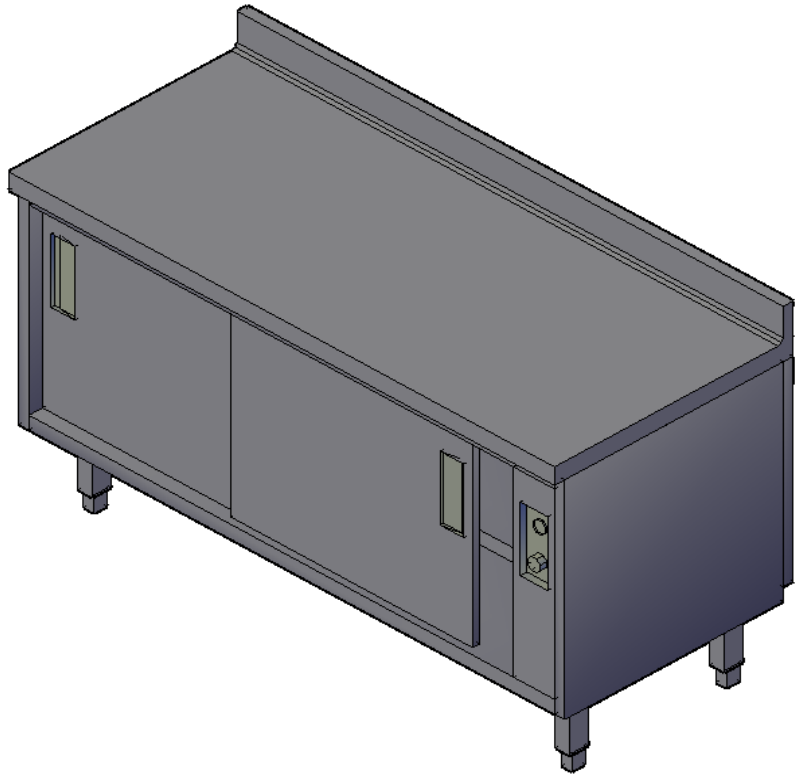

HOT CUPBOARDS WITH UPSTAND

1000/2000mm

Technical Custom Fabrication Product Description

- ☞ The ventilated hot air flow system guarantees increased temperature evenness since hot air flows throughout cabinet.
- ☞ Digital display thermostat to control the internal temperature. Internal temperature adjustable up to a maximum of 80°C.
- ☞ Made entirely from stainless steel with argon welded construction for maximum strength.
- ☞ Inner welded frame in stainless steel to guarantee superior strength and stability.
- ☞ Upstand, (splash back) 100 mm high designed to be used against a wall.
- ☞ The 50 mm high worktop in 304 AISI stainless steel, 10/10 in thickness, incorporates a layer of sound deadening and water-proof material, has upturned edges to protect the kitchen worker.
- ☞ The worktop cupboards are equipped with an intermediate shelf that can be positioned at three different heights.
- ☞ The sound-deadened sturdy sliding doors and hinged doors in 304 AISI stainless steel.
- ☞ Easy access to the cupboard interior on all lengths.
- ☞ All panel edges are upturned to guarantee the safety of the kitchen worker.
- ☞ 100 to 150 mm high AISI 304 stainless steel feet, 40mm in diameter for round legs and 40x40mm for square legs adjustable as required on site.
- ☞ All models comply with standards as far as hygiene and cleanability are concerned.
- ☞ Other option can be obtained as per requirements.

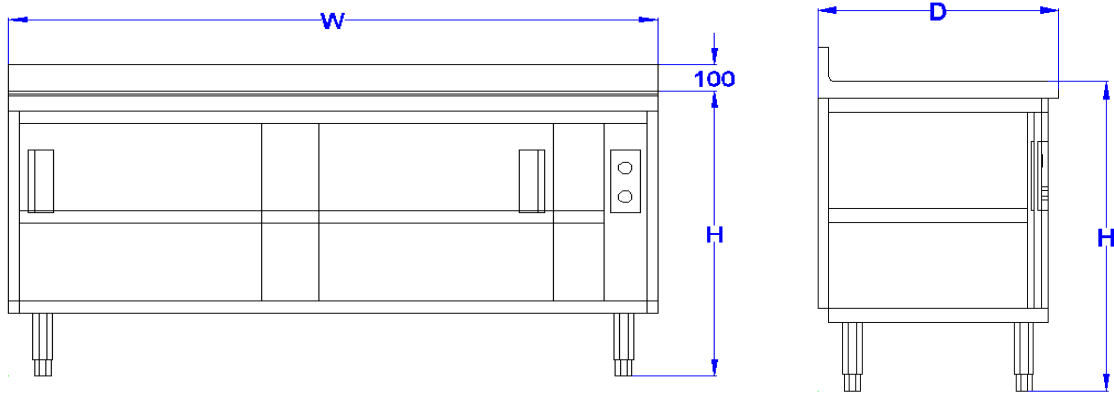

Notes: Hinged Doors are also available in different sizes as required.

TECHNICAL DATA

WIDTH	DEPTH	HEIGHT	REAR USTAND	REMARKS
1000	700	850	100	2 DOORS
1100	700	850	100	2 DOORS
1200	700	850	100	2 DOORS
1300	700	850	100	2 DOORS
1400	700	850	100	3 DOORS
1500	700	850	100	3 DOORS
1600	700	850	100	3 DOORS
1800	700	850	100	4 DOORS
2000	700	850	100	4 DOORS

All measurements are in mm



The Technical Company

P.O. Box 5090 Safat, 13051 Kuwait -Tel: +965-1800771 Fax: +965-24848310

E-mail: info@alqudaibi.com – Website: www.alqudaibi.com

A Subsidiary of QDB Holding



The Company reserves the right to alter any technical specifications without prior notice.