

Product Summary

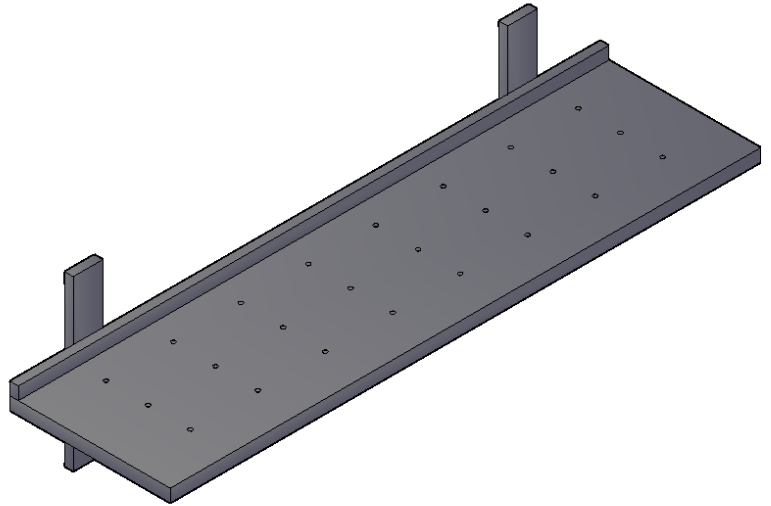



Range of Models composed of wall perforated shelf varying in length from 1000 to 2000 mm with bracket support for durability and strength.



PERFORATED WALL SHELF

1000/2000mm

Technical Custom Fabrication Product Description

-  The wide range of modular wall shelves is ideally suited to solve every storage need and rationally use the available space in the kitchen.
-  All elements made entirely in 304 AISI stainless steel, 10/10 in thickness; with a Scotch Brite finish.
-  The wall shelves are easily installed and positioned at different heights on the wall using the wall brackets supplied. Wall shelves up to a length of 1600 mm are supplied with 2 wall brackets, wall shelves 1800 mm and 2000 mm in length are supplied with 3 wall brackets.
-  All the wall shelves incorporate a rear upstand to facilitate easy cleaning, avoiding spillage between the wall and the shelf.
-  All panel edges are upturned to guarantee the safety of the kitchen worker.



TECHNICAL DATA

WIDTH	DEPTH	HEIGHT	REMARKS
1000-2000	400	40	Depends how many shelf required

All measurements are in mm



The Technical Company

P.O. Box 5090 Safat, 13051 Kuwait -Tel: +965-1800771 Fax: +965-24848310

E-mail: info@alqudaibi.com – Website: www.alqudaibi.com

A Subsidiary of QDB Holding

