







## Product Summary

The new Tandoori Oven is made of traditional style of cooking and its widely used in Persian and Middle eastern restaurants and villas.



## TCF TANDOORI OVEN

### Technical Custom Fabrication Product Description

-  Made entirely from stainless steel with argon welded construction for maximum strength.
-  Inner welded frame in stainless steel to guarantee superior strength and stability.
-  The 40 mm high worktop in 304 AISI stainless steel, and incorporates a layer of sound deadening water-proof material, has upturned edges to protect the kitchen worker.
-  Side and base panel in 304 AISI stainless steel
-  Hardened inner surface in stone clay body, hardcoated outer surface with reinforcement metal rings.
-  It can cook fish, meat, bread, chicken etc.

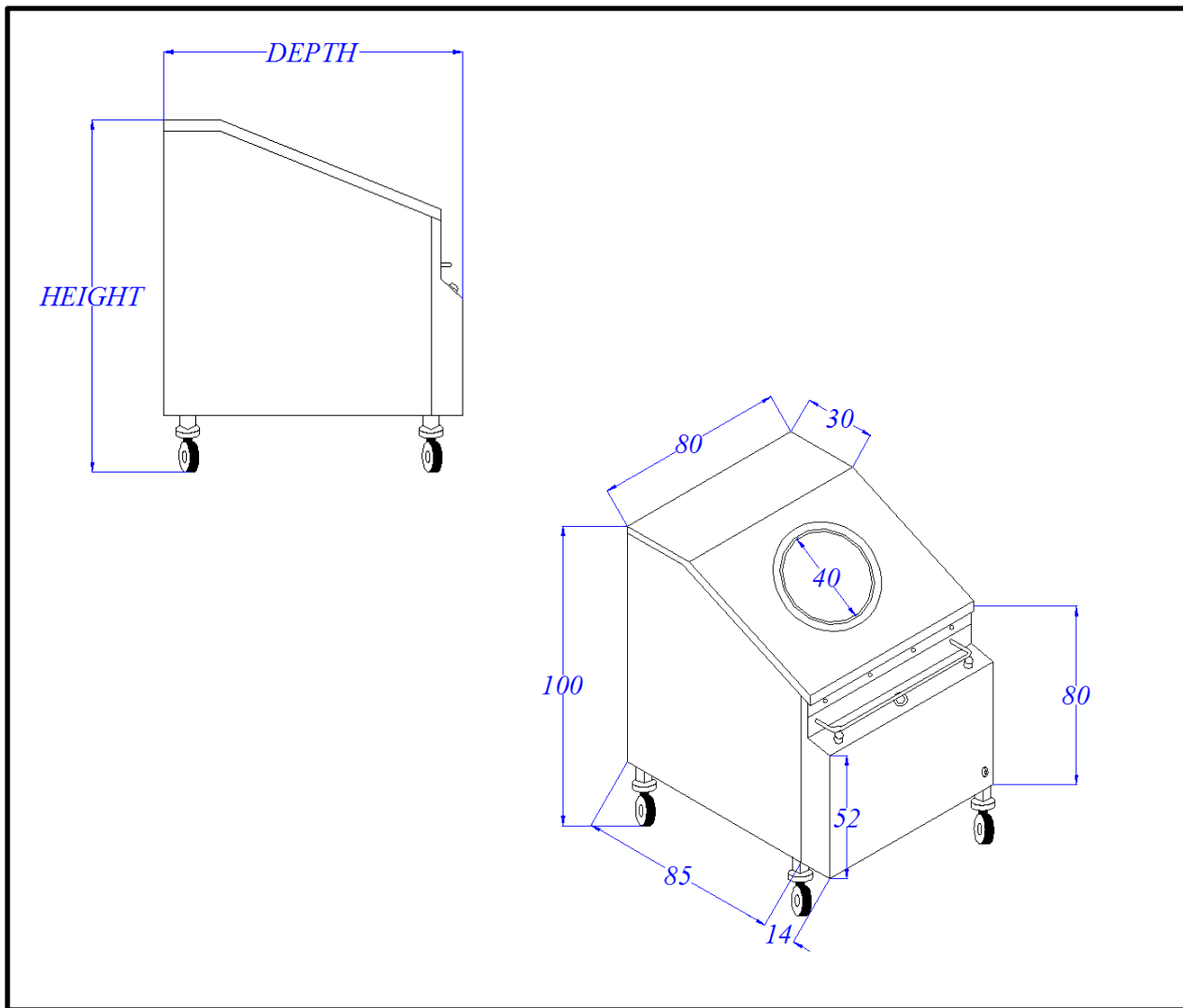

## TECHNICAL DATA

WIDTH	DEPTH	HEIGHT
800	990	1000

*All measurements are in mm*



### The Technical Company

P.O. Box 5090 Safat, 13051 Kuwait -Tel: +965-1800771 Fax: +965-24848310

E-mail: info@alqudaibi.com – Website: www.alqudaibi.com

*A Subsidiary of QDB Holding*

