

Product Summary

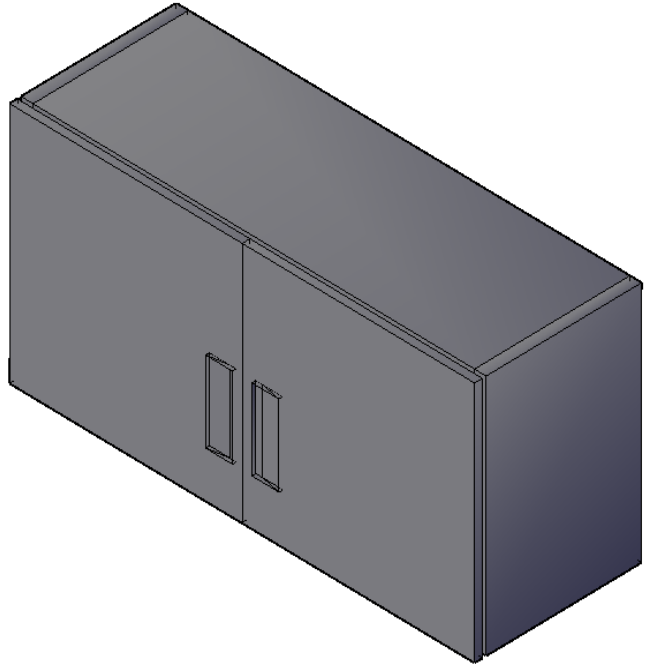





Range of Models composed of wall cupboards varying in length from 1000 to 2000 mm all with an internal shelf as standard.



WALL CUPBOARDS WITH HINGED DOORS

1000/2000mm

Technical Custom Fabrication Product Description

-  The wide range of wall cupboards with sliding doors and hinged doors are ideally suited to solve every storage need.
-  Back and bottom panels are composed of a single bended sheet for better cleanability.
-  The wall cupboards feature an handle either plastic or traditional bended steel and internal shelf which can be positioned at three different levels.
-  All panel edges are upturned to guarantee the safety of the kitchen worker
-  Available as special: lighting kits and wall panels for installation between the wall cupboard and other units with splash backs, such as tables, worktop cupboards and sinks.
-  All models comply with standards as far as hygiene and cleanability are concerned.

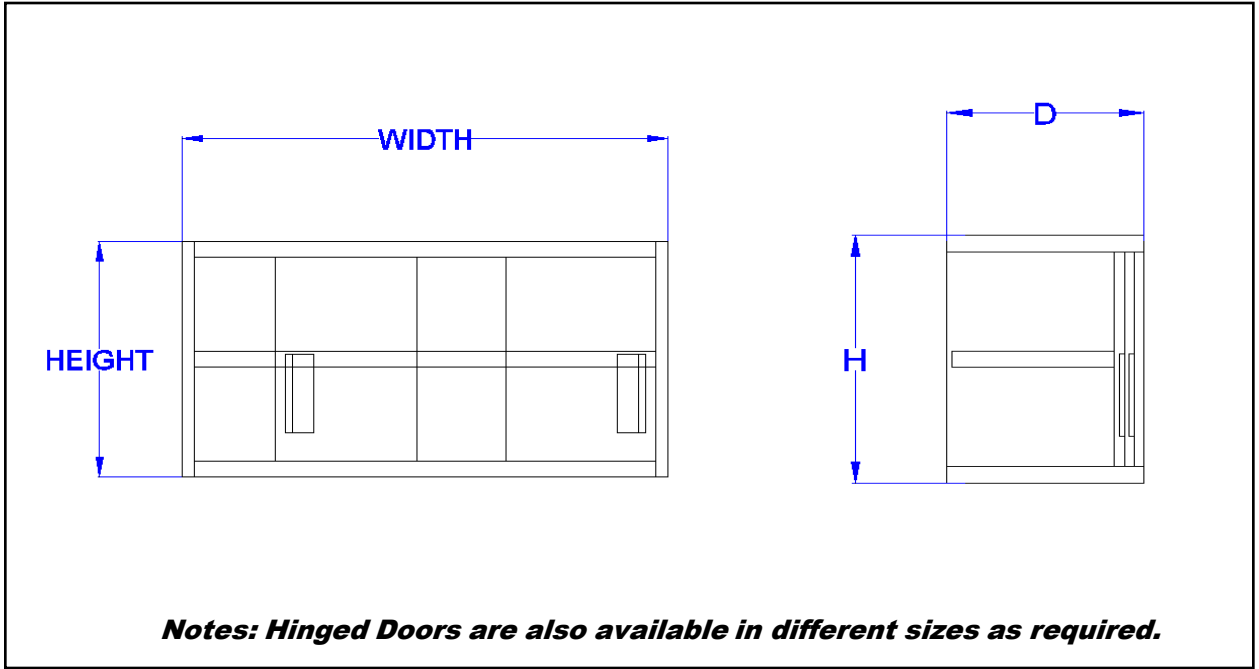

TECHNICAL DATA			
WIDTH	DEPTH	HEIGHT	REMARKS
1000	380	580	2 Doors
1100	380	580	2 Doors
1200	380	580	2 Doors
1300	380	580	2 Doors
1400	380	580	3 Doors
1500	380	580	3 Doors
1600	380	580	3 Doors
1800	380	580	4 Doors
2000	380	580	4 Doors
<i>All measurements are in mm</i>			



The Technical Company

P.O. Box 5090 Safat, 13051 Kuwait -Tel: +965-1800771 Fax: +965-24848310

E-mail: info@alqudaibi.com – Website: www.alqudaibi.com

A Subsidiary of QDB Holding

