

Product Summary

Technical Custom Fabrication offers different models of worktop cupboards with sliding doors or with hinged doors complete with splash back, varying in length from 1000 to 2000 mm. Inner space is useful to store crockery and other kitchen utensils.

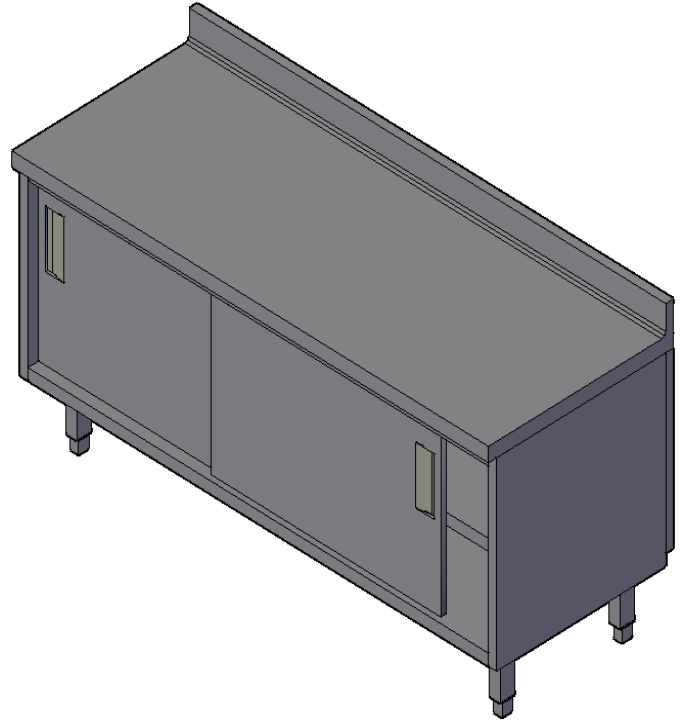

WORKTOP CUPBOARDS WITH UPSTAND

1000/2000mm

Technical Custom Fabrication Product Description

☞ Made entirely from stainless steel with argon welded construction for maximum strength.

☞ Inner welded frame in stainless steel to guarantee superior strength and stability.

☞ Splash back with 100 mm high, designed to be used against a wall.

☞ The 40 mm high worktop in 304 AISI stainless steel, and incorporates a layer of sound deadening water-proof material, has upturned edges to protect the kitchen worker. Side and base panel in 304 AISI stainless steel

☞ The worktop cupboards are equipped with an intermediate shelf that can be positioned at three different heights.

☞ The sound-deadened sturdy sliding doors and hinged doors in 304 AISI stainless steel. Easy access to the cupboard interior on all lengths.

☞ All panel edges are upturned to guarantee the safety of the kitchen worker.

☞ 100 to 150 mm high AISI 304 stainless steel feet, 40mm in diameter for round legs and 40x40mm for square legs adjustable as required on site.

☞ All models comply with standards as far as hygiene and cleanability are concerned.

☞ Other options can be obtained as per requirements.

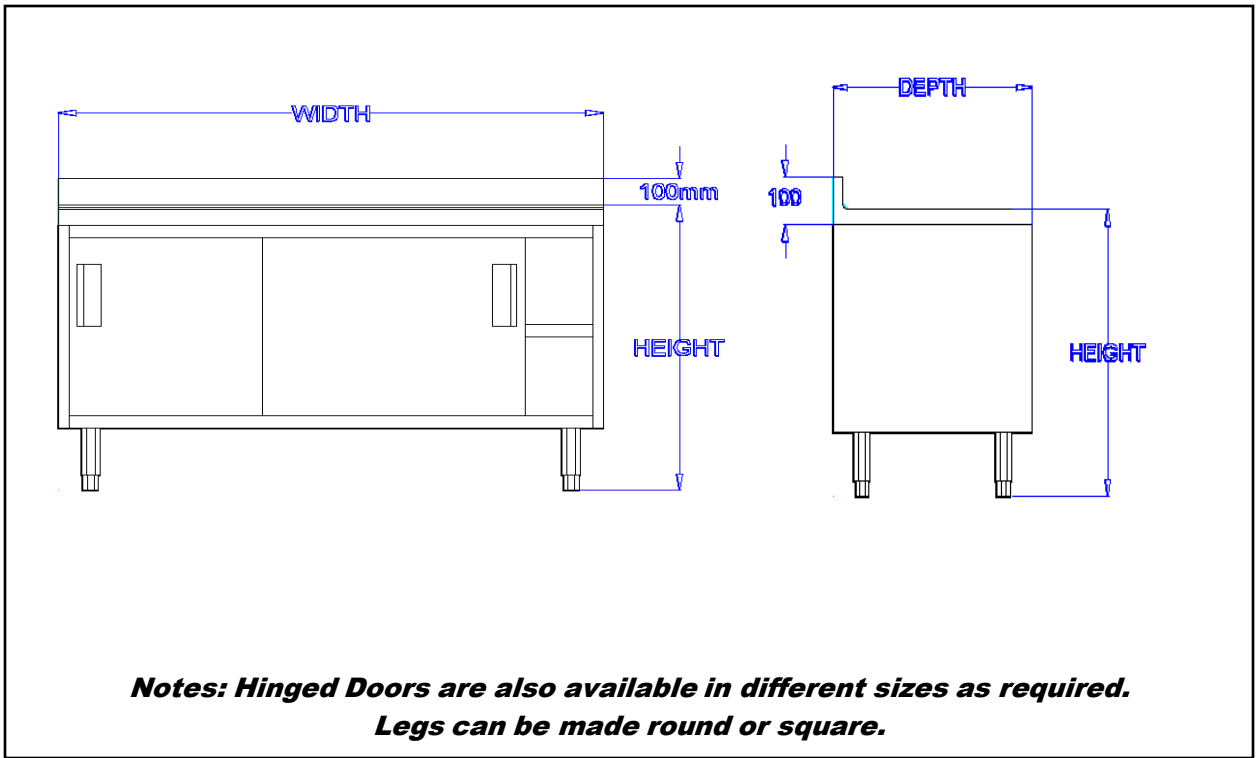

TECHNICAL DATA				
WIDTH	DEPTH	HEIGHT	REAR UPSTAND (AVAILABLE IN ANY SIZE)	REMARKS
1000	700	850	100	2 Doors
1100	700	850	100	2 Doors
1200	700	850	100	2 Doors
1300	700	850	100	2 Doors
1400	700	850	100	3 Doors
1500	700	850	100	3 Doors
1600	700	850	100	3 Doors
1800	700	850	100	4 Doors
2000	700	850	100	4 Doors
<i>All measurements are in mm</i>				



The Technical Company

P.O. Box 5090 Safat, 13051 Kuwait -Tel: +965-1800771 Fax: +965-24848310
E-mail: info@alqudaibi.com – Website: www.alqudaibi.com

A Subsidiary of QDB Holding

